



DIESEL 3.0L

150 / 230 / 270



REDEFINING THE STANDARD

The new Mercury Diesel 3.0L common-rail highspeed engine delivers exceptional performance and offers substantial improvements in acceleration and top speed – all made possible via a new water-cooled variable geometry turbocharger design (VGT). This matched system, plus a state-of-the-art engine control system, provides reduced time to plane and outstanding overall performance.

This powerful, compact package can fit in virtually any installation while low fuel consumption results in affordable operating costs and extended travel range.

The new Mercury Diesel 3.0L highspeed engine was designed to be durable, with features and materials specific to marine applications, and it proved itself by meeting Mercury’s rigorous test standards. The new engine is assembled in a state-of-the-art manufacturing facility that employs the latest in quality practices and controls, further underscoring confidence in reliability.

Mercury Diesel’s 3.0L engine is compatible with all Mercury controls and SmartCraft® electronics and is serviceable through Mercury’s global service network. Mercury Diesel’s SmartCraft compatibility offers boaters a choice between conventional mechanical throttle and shift or digital throttle and shift (DTS). Mercury’s Digital Throttle and Shift (DTS) system includes optional Joystick Piloting for Inboards (JPI) and Joystick Piloting for Sterndrives (JPS).

General Specifications	
Configuration	6 cylinder (V-6), 4 stroke diesel
Bore and Stroke	mm (inch) 83 x 92 (3.27 x 6.62)
Displacement	L (in3) 3.0 (183)
Air handling	Turbocharged and Aftercooled
Fuel system	High pressure common rail
Rotation	Counter Clockwise facing flywheel

Bobtail Dimensions and Weight	
Overall length	mm (inch) 931 (36.6)
Overall width	mm (inch) 851 (33.5)
Overall height	mm (inch) 784 (30.9)
Dry weight SD/IB	358kg (789lbs) / 348kg (767lbs)

**Weight includes engine mount supports, alternator, and engine cover*





Propulsion System	Model	3.0L 150	3.0L 230	3.0L 270	Weight (kg/lb)
Sterndrive*	Bravo One X	1.36:1 / 1.50:1 / 1.65:1	1.36:1 / 1.50:1 / 1.65:1	1.36:1 / 1.50:1 / 1.65:1	100 / 220
	Bravo Two X	1.50:1 / 1.65:1 / 1.81:1 2.00:1 / 2.20:1	1.50:1 / 1.65:1 / 1.81:1 2.00:1 / 2.20:1	1.50:1 / 1.65:1 / 1.81:1 2.00:1 / 2.20:1	105 / 231
	Bravo Three X	1.36:1 / 1.50:1 / 1.65:1 1.81:1 / 2.00:1 / 2.20:1	1.36:1 / 1.50:1 / 1.65:1 1.81:1 / 2.00:1 / 2.20:1	1.36:1 / 1.50:1 / 1.65:1 1.81:1 / 2.00:1 / 2.20:1	109 / 240
	Bravo One XR	1.36:1 / 1.50:1	1.36:1 / 1.50:1	1.36:1 / 1.50:1	100 / 220
	Bravo Two XR	1.65:1	1.65:1	1.65:1	105 / 231
	Bravo Three XR	1.65:1 / 1.81:1 / 2.00:1	1.65:1 / 1.81:1 / 2.00:1	1.65:1 / 1.81:1 / 2.00:1	109 / 240
Inboard	ZF 45C	-	1.00:1	1.00:1	31 / 69
	ZF 63	-	1.25:1 / 1.75:1 / 2.78:1	1.25:1 / 1.75:1 / 2.78:1	46 / 103
	ZF 63A	-	1.21:1 / 1.56:1 / 2.03:1 / 2.52:1 / 2.68:1	1.21:1 / 1.56:1 / 2.03:1 / 2.52:1 / 2.68:1	44 / 97
	ZF 63IV/68IV	-	1.29:1 / 1.56:1 / 1.99:1	1.29:1 / 1.56:1 / 1.99:1	62 / 136

*Weights reflect sterndrive & transom

PACK A PUNCH

DIESEL

Mercury Diesel engines offer an exhilarating yet refined diesel-engine experience: Advanced turbocharging and injection technologies produce a powerband that's precisely calibrated for marine performance and outstanding economy. Lightweight designs boost performance further, while clean and quiet operation enhance your day on the water.



3.0L



150 / 230 / 270
STERNDRIVE

Engine

- Aluminum cylinder heads
- Compacted Graphite Iron cylinder block, light weight, high strength with max heat transfer for optimal cooling
- Block, 60-degree V-6
- Fracture split connecting rods
- Front chain driven timing system
- Glow plug system standard

Fuel System

- Bosch CP4.2 w/ integrated gear driven lift pump
- Bosch CRS 2.2 solenoid fuel injectors
- Engine mounted 4 micron filter protecting the system

Engine Controls

- Bosch EDC17 Controller
- Controller rubber isolated, mounted to ensure durability

Air Intake

- Air filter / Silencer included for noise reduction

Turbo Charger

- Single turbo
- Electrically actuated VGT
- Oil and Glycol cooled Center section
- Glycol cooled Turbine housing

Exhaust System

- Closed cooled manifold
- Closed cooled turbocharger
- Seawater cooled riser

Electrical System

- 12 V
- High output alternator 12V 110 Amp

3.0L



230 / 270
INBOARD

Cooling System

- Thermostatically controlled
- Closed cooled engine for corrosion protection
- Seawater cooled charge air cooler
- Standard cabin heater connections
- On-engine sea strainer
- Seawater cooled fuel cooler

Emissions

- EPA Tier 3
- RCD 2
- IMO Tier 2
- BSO 2

FRONT VIEW FEATURES

1. Raw Water Pump
2. High Pressure Fuel Pump
3. Coolant Resivior
4. Optional Belt Cover

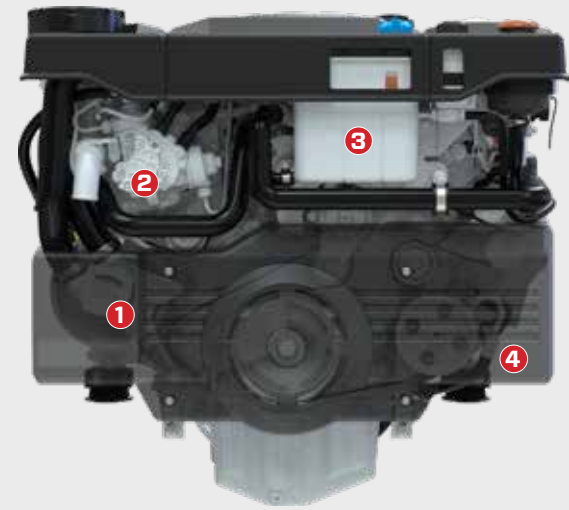

TOP VIEW FEATURES

1. Fuse Box
2. MerCathode LED

PORT SIDE VIEW FEATURES

1. Diagnostic Port
2. Alternator
3. ECU
4. Engine Oil Cooler
5. Oil Filter
6. Hot Stud
7. Riser



REAR VIEW FEATURES

1. Water Cooled VGT Turbo Charger
2. Turbo Compressor
3. Air filter & Silencer
4. Engine mount
5. Power Steering Cooler



TOP VIEW FEATURES

1. Maintenance label decal
2. Oil fill cap
3. Coolant fill
4. Drive lube (sterndrive only)
5. Power steering (sterndrive only)



STARBOARD SIDE VIEW FEATURES

1. Heat exchanger
2. Shift plate
3. Dip stick
4. On engine sea water strainer

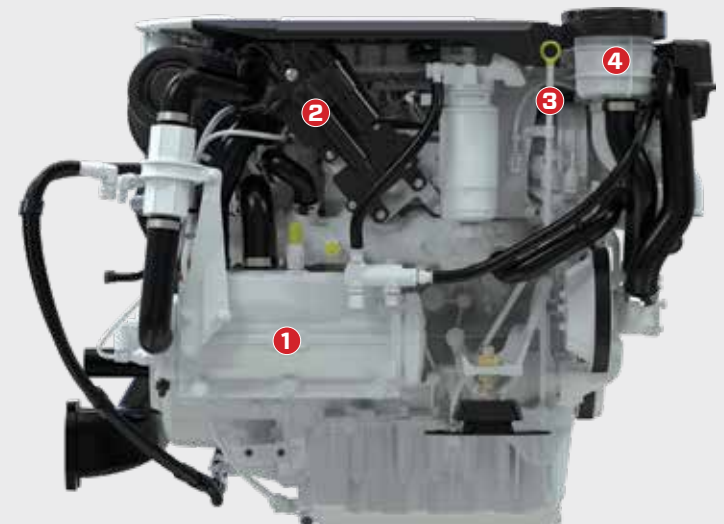

Specifications	150 mHP	230 mHP	270 mHP
Compression ratio	16.5:1		
Fuel pre-filtration requirement	Not required but feasible		
Fuel lift pump	On engine		
High pressure fuel pump	Bosch CP 4.2 w/integrated gear lift pump		
Valves per cylinder	4		
Pistons	Oil jet cooled		
Fuel injectors	Bosch CRS 2.20 (Solenoid)		
Air Inlet (Port rear)	Filtered and silenced		
Turbocharger	Honeywell VGT		
Engine and turbocharger cooling	Closed cooled		
Coolers; CAC, Oil, Fuel and Engine	Tube and Shell		
Seawater pump/inlet mm (in)	38 mm (1.5in)		
Peak torque at RPM N-m (ft-lb)	493 Nm @ 2000 rpm	503 Nm @ 2200 rpm	594 Nm @ 2200 rpm
Oil sump volume L (qt)	8.5L		
Dipstick range L (qt)	1.0L		
Oil maintenance interval hr*	200		
Flywheel size mm (in)	290 (11.42)		
Flywheel housing	SAE 8		
Electrical system	12V 110A		
Engine stop	ECU Controlled		
Engine Control Unit (ECU)	Bosch EDC17		
Throttle and shift	Mercury DTS or Mechanical Cable		
Helm and gauge compatibility	Mercury SmartCraft		
Mercury Joystick Piloting - Inboard & Sterndrive	Compatible		
Engine and ECU covers	Texture coated Aluminum. Protects engine plus provides step capable platform		
Inboard: ZF 63A	1.21, 1.56, 2.03, 2.52, 2.68		
Inboard: ZF 63	1.25, 1.75, 2.78		
Inboard: ZF 68IV	1.29, 1.56, 1.99		
Inboard: ZF 45C	1.00		
Sensors	Crank & cam position, intake manifold pressure/temp, compressor outlet temp, exhaust gas temp, fuel temp, rail pressure, water in fuel (WIF), oil pressure/temp, coolant temp, seawater pressure/temp, atmospheric pressure		

Model	Driveline Options	Output Power		Fuel use at Rated Speed L/hr (gal/hr)	Rated Use	Idle Speed (RPM)	Max Rated Engine Speed (RPM)	Emissions Ratings (no after treatment)		
		mHP	kW					EPA	EU	IMO
150	Bobtail Inboard	150	110	31.5 (8.3)	LDC	650	3000	Tier 3	RCD 2	Tier 2
230	Bobtail Inboard	230	169	49 (12.9)	REC/LDC		4200	Tier 3		
270	Bobtail Inboard	270	199	55 (14.3)						

ENGINE DIMENSIONS - INBOARD

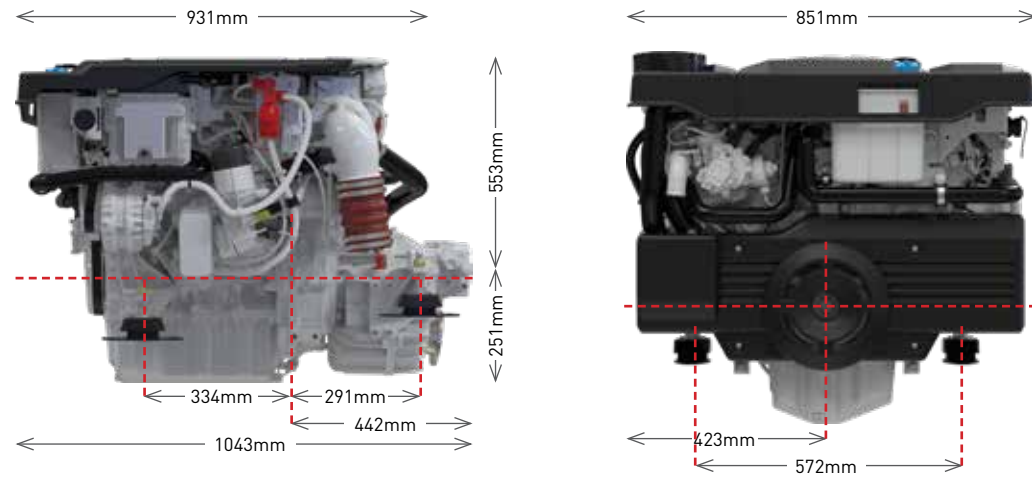

ENGINE DIMENSIONS - STERNDRIVE

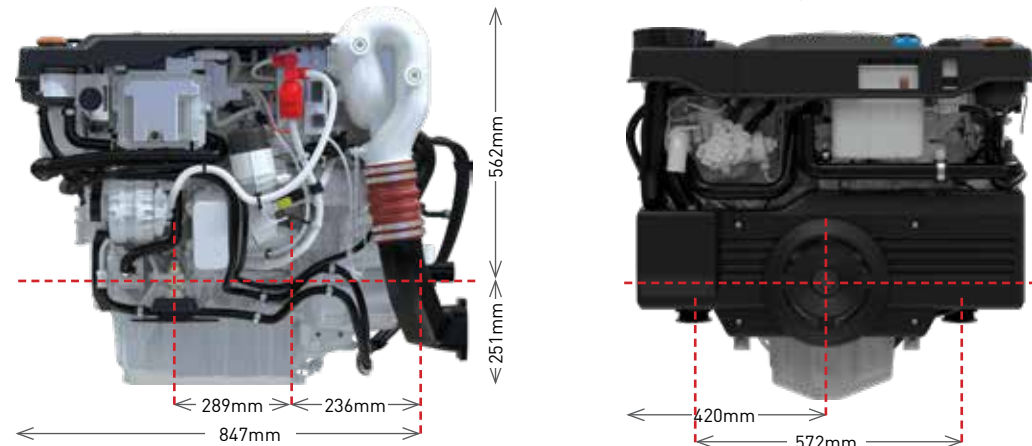

TORQUE & POWER (full load at crankshaft)

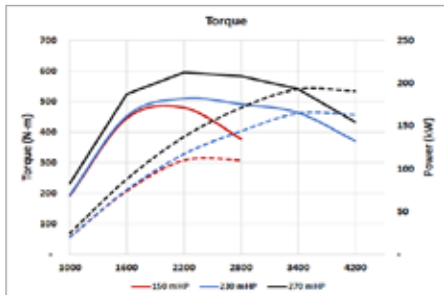

BOAT LOAD FUEL CONSUMPTION

